



Automatic Snow/Ice Melting System Peripheral

MODEL SC-40 SATELLITE CONTACTOR

BENEFITS

- Low cost control of larger snow melting systems

FEATURES

- Contactor rating of 50 amps per pole
- Supply options: 208, 240, 277, 480 and 600 volts
- Single and three-phase power control
- Integral 30 mA GFCI
- U-L Listed, CSA Certified
- Self-test feature
- Simple installation
- Low Cost

DESCRIPTION

The patented SC-40 Satellite Contactor is a power control peripheral for a APS-4 Snow Switch® Control Panel. The APS-4 operates the SC-40 whenever its contactor operates. That is, during snow and for the hold-on time thereafter.

The integral 30 mA ground fault circuit interrupter (GFCI) along with a test/reset facility ensure safety along with NEC and local code compliance. Partitioning heater loads for multiple SC-40 prevents the nuisance GFCI tripping that is often unavoidable when controlling a large system with a single contactor. The self-test facility operates heaters for one minute with a duty cycle limited to 33% for safer heater testing during the summer months.

One APS-4 operates up to ten SC-40. The size and location of the heaters determines the number of SC-40 required. The APS-4 and its SC-40 can be separated by up to 1,000ft (305m).

Supply voltage options include 240 single phase or 208, 277, 480 and 600 volts 3 phase, with a contactor rating of 50 amps per pole. For installation simplicity, SC-40 control wiring is NEC Class 2.

The SC-40's non-metallic enclosure is rated for protected NEMA 3R locations in the temperature range of -40° to 160° F (-40° to 60° C).

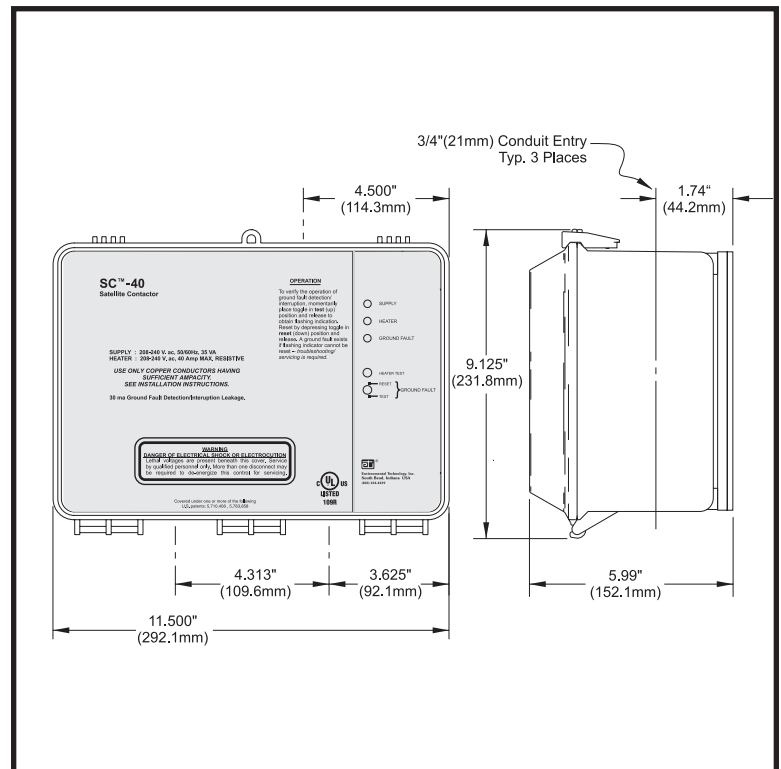

Environmental Technology, Inc.
1850 N Sheridan Street
South Bend, IN 46601 USA

continued...

INSTALLATION

Install in accordance with the requirements of all applicable electrical and building codes and regulations.

The SC-40 nonmetallic enclosure is furnished with three 3/4" (21mm) conduit openings; if installed in a hostile environment, ensure that all conduit terminations are watertight.

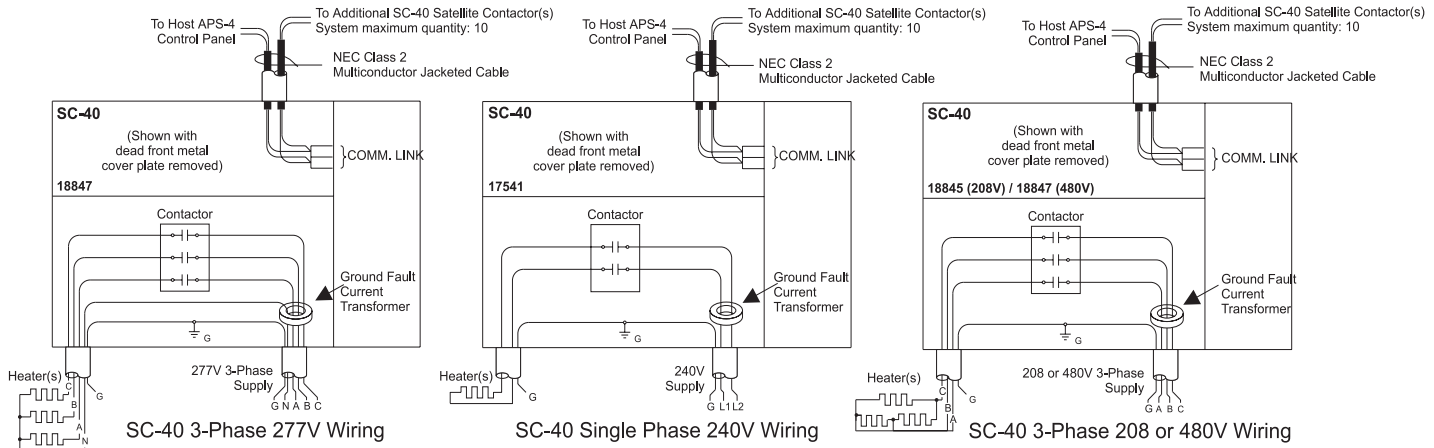

ORDERING INFORMATION

<u>Order Number</u>	<u>Description</u>
17710	SC-40 Satellite Contactor, 277 VAC Single Phase
17541	SC-40 Satellite Contactor, 240 VAC Single Phase
18845	SC-40 Satellite Contactor, 208 VAC Three Phase
18847	SC-40 Satellite Contactor, 277 / 480 VAC Three Phase
19609	SC-40 Satellite Contactor, 600 VAC Three Phase

LIMITED WARRANTY

ETI's two year limited warranty covering defects in workmanship and materials applies. Contact Customer Service for complete warranty information.

DISCLAIMER

Environmental Technology, Inc. makes no representations or warranties, either expressed or implied, with respect to the contents of this publication or the products that it describes, **and specifically disclaims any implied warranties of merchantability or fitness for any particular purpose.** Environmental Technology, Inc. reserves the right to revise this publication, and to make changes and improvements to the products described in this publication, without the obligation of Environmental Technology, Inc. to notify any person or organization of such revisions, changes or improvements.



1850 N Sheridan Street, South Bend, IN 46628 (574) 233-1202/Fax (574) 233-2152/Toll Free (800) 234-4239/Toll Free Fax (888) 234-4238
<http://www.networketi.com> / e-mail: info@networketi.com

The ETI logo, Snow Switch, Floorstat, Tracon, We Provide Managed Heat, We Manage Heat are registered trademarks of Environmental Technology, Inc. 99+, ADH, APS, CIT, EDH, EUR, ES, FMC, FWT, GIT GPT, HSC, LCD, RCD, RCU, RMC, SIT, and are Environmental Technology, Inc. trade marks. Copyright © 2000 Environmental Technology, Inc. All rights reserved.

10/2010 18632A